

COLORDash Par-H12 IP

User Manual

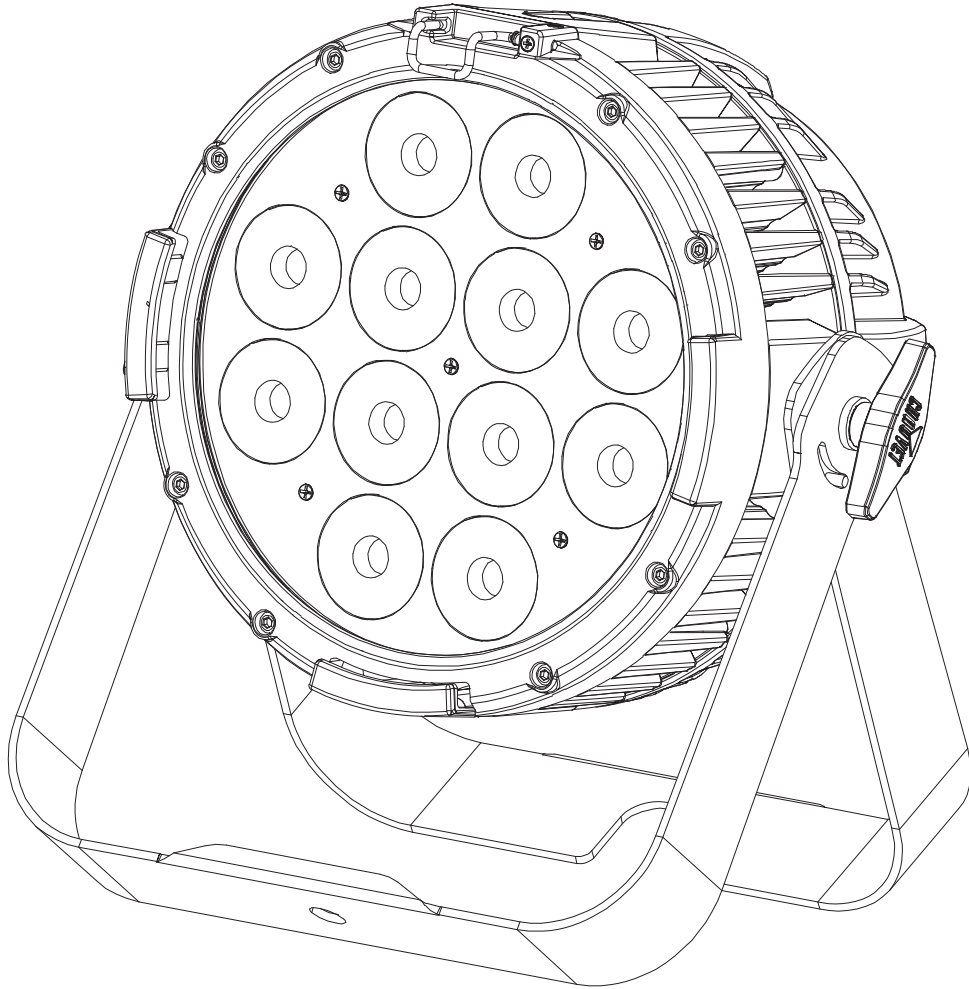

CHAUVET
PROFESSIONAL

EDITION NOTES

The COLORdash Par-H12 IP User Manual includes a description, safety precautions, installation, programming, operation and maintenance instructions for the COLORdash Par-H12 IP as of the release of this edition.

Trademarks

CHAUVET, the Chauvet logo and COLORdash Par-H12 IP are registered trademarks or trademarks of Chauvet & Sons, LLC (d/b/a Chauvet and Chauvet Lighting) in the United States and other countries. Other company and product names and logos referred to herein may be trademarks of their respective companies.

Copyright Notice

The works of authorship contained in this manual, including, but not limited to, all design, text and images are owned by Chauvet.

© Copyright 2017 Chauvet & Sons, LLC. All rights reserved.

Electronically published by Chauvet in the United States of America.

Manual Use

Chauvet authorizes its customers to download and print this manual for professional information purposes only. Chauvet expressly prohibits the usage, copy, storage, distribution, modification, or printing of this manual or its content for any other purpose without written consent from Chauvet.

Document Printing

For best results, print this document in color, on letter size paper (8.5 x 11 in), double-sided. If using A4 paper (210 x 297 mm), configure the printer to scale the content accordingly.

Intended Audience

Any person installing, operating, and/or maintaining this product should completely read through the guide that shipped with the product, as well as this manual, before installing, operating, or maintaining this product.

Disclaimer

Chauvet believes that the information contained in this manual is accurate in all respects. However, Chauvet assumes no responsibility and specifically disclaims any and all liability to any party for any loss, damage or disruption caused by any errors or omissions in this document, whether such errors or omissions result from negligence, accident or any other cause. Chauvet reserves the right to revise the content of this document without any obligation to notify any person or company of such revision, however, Chauvet has no obligation to make, and does not commit to make, any such revisions. Download the latest version from www.chauvetprofessional.com

Document Revision

This COLORdash Par-H12 IP User Manual is the 1st edition of this document. Go to www.chauvetprofessional.com for the latest version.

TABLE OF CONTENTS

1. Before You Begin	3
What Is Included	3
Claims	3
Manual Conventions	3
Symbols	3
Safety Notes.....	4
Personal Safety.....	4
Mounting and Rigging	4
Power and Wiring.....	4
Operation	4
Expected LED Lifespan.....	4
2. Introduction	5
Description	5
Features.....	5
Product Overview.....	6
Product Dimensions.....	7
3. Setup	8
AC Power.....	8
AC Plug.....	8
Power Linking.....	8
DMX Linking.....	9
DMX Personalities.....	9
Master/Slave Connectivity.....	9
Mounting	10
Orientation.....	10
Rigging	10
Procedure.....	10
4. Operation	11
Control Panel Operation.....	11
Control Options	11
Programming.....	11
Control Panel Lock.....	11
Passcode	11
Menu Map	12
Configuration (DMX)	14
DMX Personalities.....	14
DMX Control.....	14
DMX Values	15
13Ch.....	15
8 Ch.....	16
6 Ch.....	16
Configuration (Standalone)	16
Auto Programs	16
Master/Slave	16
White Balance	17
Static Fixed Color.....	17
Static Manual Color.....	17
Color Temperature	17
Dimmer Profiles.....	17
LED Frequency	17
Back Light	18

Fixture Hours/Software Version	18
Factory Reset.....	18
5. Technical Information	19
Product Maintenance	19
6. Technical Specifications	20
7. Returns	21
8. Contact Us	22

1. BEFORE YOU BEGIN

What Is Included

- COLORdash Par-H12 IP
- Seetronic Powerkon IP65 power cord
- Gel Frame
- Warranty Card
- Quick Reference Guide

Claims

Carefully unpack the product immediately and check the container to make sure all the parts are in the package and are in good condition.





If the box or the contents (the product and included accessories) appear damaged from shipping, or show signs of mishandling, notify the carrier immediately, not Chauvet. Failure to report damage to the carrier immediately may invalidate your claim. In addition, keep the box and contents for inspection.

For other issues, such as missing components or parts, damage not related to shipping, or concealed damage, file a claim with Chauvet within 7 days of delivery.

Manual Conventions

Convention	Meaning
1–512	A range of values
50/60	A set of values of which only one can be chosen
<SET>	A button on the product’s control panel
Settings	A product function or a menu option

Symbols

Symbol	Meaning
	Electrical warning. Not following these instructions may cause electrical damage to the product, accessories, or the user.
	Critical installation, configuration, or operation information. Not following these instructions may make the product not work, cause damage to the product, or cause harm to the operator.
	Important installation or configuration information. The product may not function correctly if this information is not used.
	Useful information.



Any reference to data or power connections in this manual assumes the use of Seetronic IP rated cables.



The term “DMX” used throughout this manual refers to the USITT DMX512-A digital data transmission protocol.

Safety Notes

Read all the following safety notes before working with this product. These notes contain important information about the installation, usage, and maintenance of this product.



This product contains no user-serviceable parts. Any reference to servicing in this User Manual will only apply to properly trained, certified technicians. Do not open the housing or attempt any repairs.



All applicable local codes and regulations apply to proper installation of this product.

Personal Safety

- Avoid direct eye exposure to the light source while the product is on.
- Always disconnect the product from the power source before cleaning or replacing the fuse.
- Always connect the product to a grounded circuit to avoid the risk of electrocution.
- Do not touch the product's housing when operating because it may be very hot.

Mounting and Rigging

- Do not submerge this product (IP65). Temporary outdoor operation is fine.
- When using this product in an outdoor environment, use IP65 (or higher) rated power and data cables. Secure unused power and data ports with attached IP65 covers.
- CAUTION: When transferring product from extreme temperature environments, (e.g., cold truck to warm, humid ballroom) condensation may form on the internal electronics of the product. To avoid causing a failure, allow product to fully acclimate to the surrounding environment before connecting it to power.
- Not for permanent outdoor installation in locations with extreme environmental conditions. This includes, but is not limited to:
 - Exposure to a marine/saline environment (within 3 miles of a saltwater body of water).
 - Locations where the normal high or low temperatures exceed the temperature ranges in this manual.
 - Locations that are prone to flooding or being buried in snow.
 - Areas where the product will be subjected to extreme radiation or caustic substances.
- Mount this product in a location with adequate ventilation, at least 20 in (50 cm) from adjacent surfaces.
- Make sure there are no flammable materials close to the product when operating.
- When hanging this product, always secure to a fastening device using a safety cable.

Power and Wiring

- Always make sure you are connecting the product to the proper voltage in accordance with the specifications in this manual or on the product's specification label.
- Never connect the product to a dimmer pack or rheostat.
- Never disconnect this product by pulling or tugging on the power cable.

Operation

- Do not operate this product if there is damage on the housing, lenses, or cables. Have the damaged parts replaced by an authorized technician at once.
- Do not cover the ventilation slots when operating to avoid internal overheating.
- The maximum ambient temperature is 113 °F (45 °C). Do not operate the product at higher temperatures.
- In the event of a serious operation problem, stop using this product immediately!



If your Chauvet product requires service, contact Chauvet Technical Support.

Expected LED Lifespan

LEDs gradually decline in brightness over time, primarily because of heat. LEDs that are arranged in clusters experience higher operating temperatures than single LEDs. For this reason, operating clustered LEDs at their fullest intensity significantly reduces the LEDs' lifespan. Under normal conditions, this lifespan is 40,000 to 50,000 hours. If extending this lifespan is vital, lower the operating temperature by improving the ventilation around the product, thus reducing the ambient temperature. In addition, limiting the overall projection intensity may extend the LEDs' lifespan.

2. INTRODUCTION

Description

The COLORdash Par-H12 IP delivers an intense and beautiful RGBAW + UV LED wash in any weather condition. An OLED full text display is easy to navigate and direct IP rated connections for power and DMX make setup a breeze. The product is fully convection cooled.

Features

- 6, 8 or 13-channel hex-color LED wash product
- Operating modes:
 - 6-channel: RGBAWP
 - 8-channel: RGBAWP, dimmer, strobe
 - 13-channel: RGBWAP, dimmer, strobe, color macro/white balance, auto speed, dimmer speed
- Rugged RGBWA-UV LED wash for events where indoor/outdoor flexibility is needed
- At home in any weather conditions with IP rated power and DMX connections
- Adjustable PWM (Pulse Width Modulation) to avoid flickering on camera
- RDM (Remote Device Management) for added flexibility
- Selectable, smooth dimming curves for eliminate flicker and choppiness in fades
- Easy to read OLED display with password protection and touchscreen interface
- Advanced optics provide exceptional color mixing and high efficiency
- Double-bracketed yoke doubles as floor stand

Product Overview

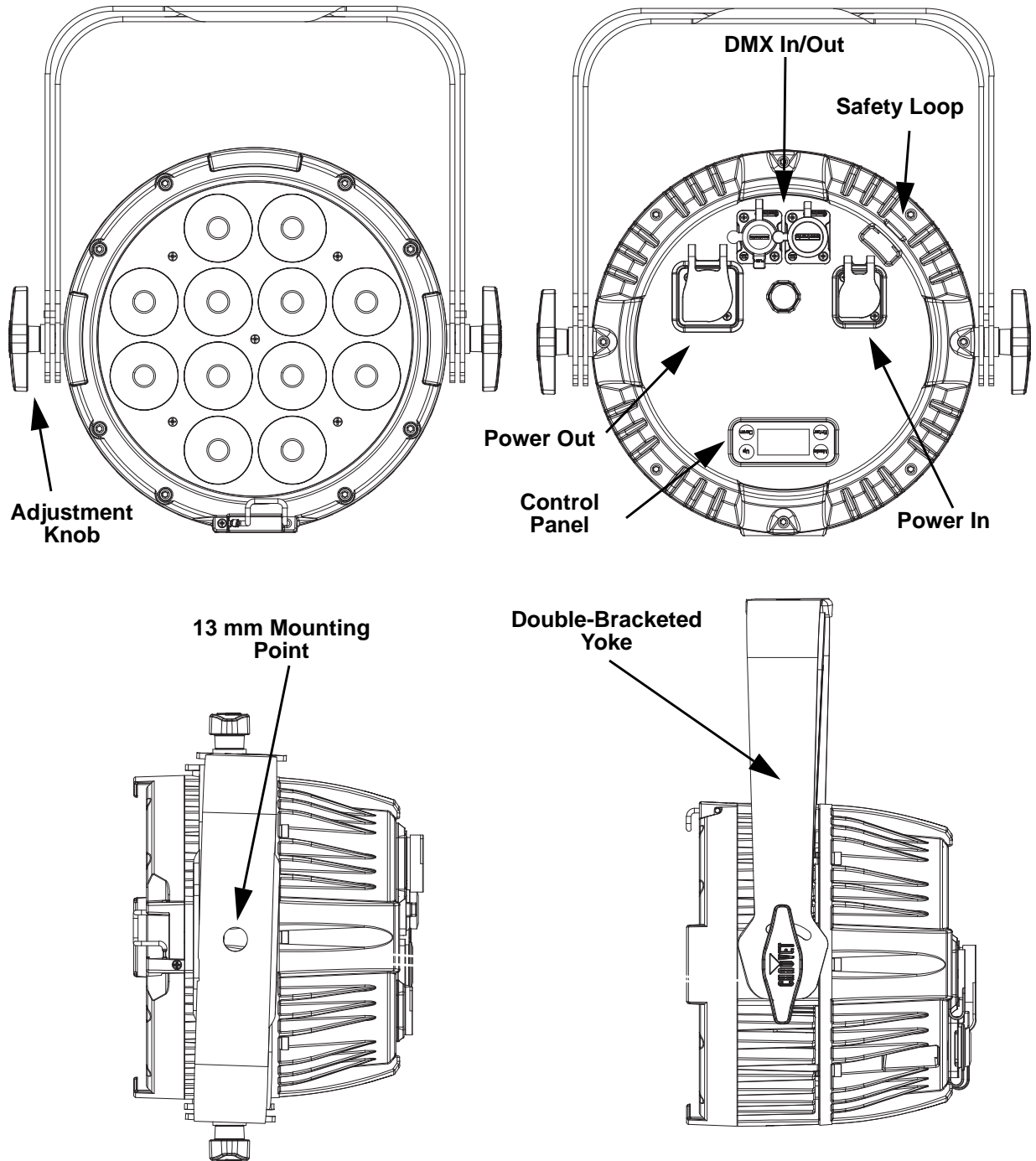

Product Dimensions

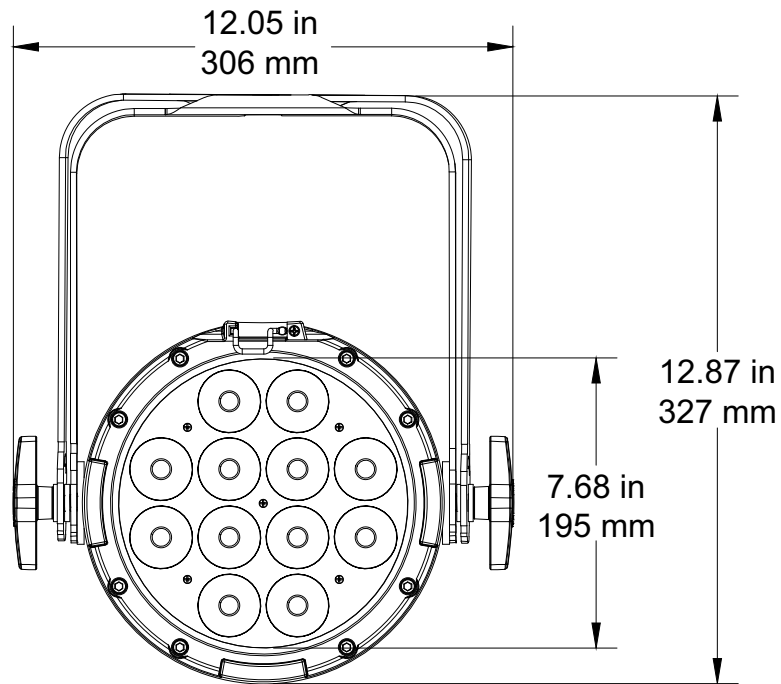
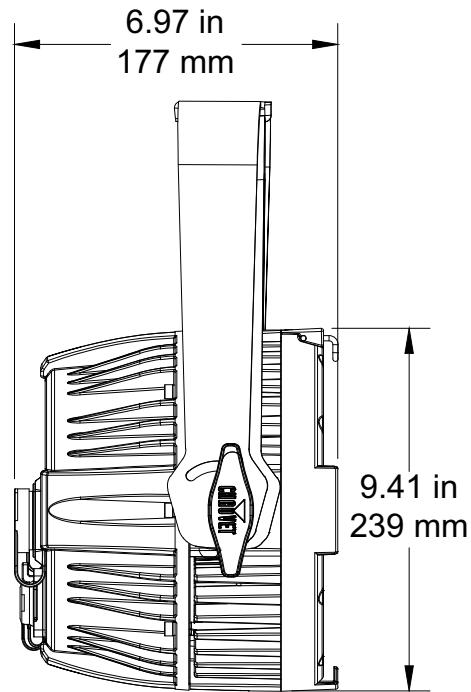

3. SETUP

AC Power

Each COLORdash Par-H12 IP has an auto-ranging power supply that works with an input voltage range of 100 to 240 VAC, 50/60 Hz. To determine the power requirements for each COLORdash Par-H12 IP, refer to the label affixed to the product. You can also refer to the Technical Specifications chart in this manual.

The listed current rating indicates the maximum current draw during normal operation. For more information, download Sizing Circuit Breakers from the Chauvet website: www.chauvetprofessional.com.



- **Always connect the product to a protected circuit (circuit breaker or fuse). Make sure the product has an appropriate electrical ground to avoid the risk of electrocution or fire.**
- **To eliminate unnecessary wear and improve its lifespan, during periods of non-use completely disconnect the product from power via breaker or by unplugging it.**



Never connect the product to a rheostat (variable resistor) or dimmer circuit, even if the rheostat or dimmer channel serves only as a 0 to 100% switch.

AC Plug

The COLORdash Par-H12 IP comes with a power input cord terminated with a Seetronic Powerkon A connector on one end and an Edison plug on the other end (U.S. market). If the power input cord that came with your product has no plug, or if you need to change the plug, use the table below to wire the new plug.

Connection	Wire (U.S.)	Wire (Europe)	Screw Color
AC Live	Black	Brown	Yellow or Brass
AC Neutral	White	Blue	Silver
AC Ground	Green/Yellow	Green/Yellow	Green

Power Linking

The product supports power linking. You can power link up to 26 products at 120 V; up to 46 at 208 V; or up to 50 at 230 V.

This product comes with a power input cord. Power linking cables are available from Chauvet for purchase.



- **To preserve the IP65 rating and the warranty of this product Seetronic Powerkon cables must be used.**
- **Insert the attached IP65 rated plugs into the corresponding power/data connections when not in use.**

DMX Linking

You can link the COLORdash Par-H12 IP to a DMX controller using a 5-pin DMX connection. If using other DMX-compatible products with this product, you can control each individually with a single DMX controller.

DMX Personalities

The COLORdash Par-H12 IP uses a 5-pin DMX data connection for the 6-, 8- and 13-channel DMX personalities.

- Refer to the Introduction for a brief description of each DMX personality.
- Refer to the Operation chapter to learn how to configure the COLORdash Par-H12 IP to work in these personalities.
- The DMX Values section provides detailed information regarding the DMX personalities.

Master/Slave Connectivity

The Master/Slave mode allows a COLORdash Par-H12 IP (the master) to control one or more COLORdash Par-H12 IP products (the slaves) without a DMX controller. One COLORdash Par-H12 IP becomes the master when running an auto or custom program, or by being in a Static mode.

You must configure each slave's control panel to operate in Slave mode. During Master/Slave operation, the slaves will operate in unison with the master.



DO NOT connect a DMX controller to products operating in Master/Slave mode. The DMX controller signals may interfere with the signals from the master.



- The [Operation](#) section of this manual provides detailed instructions on how to configure the master and slaves.
- If you are not familiar with, or need more information about, DMX standards, or the DMX cables needed to link this product to a DMX controller, download the DMX Primer from the Chauvet website: www.chauvetprofessional.com.



To preserve the IP65 rating and the warranty of this product, IP65 data cables must be used.

Mounting

Before mounting the product, read and follow the safety recommendations indicated in the Safety Notes. For our CHAUVET Professional line of mounting clamps, go to <http://trusst.com/products/>.

Orientation

Always mount this product in a safe position, making sure there is adequate room for ventilation, configuration, and maintenance.

Rigging

Chauvet recommends using the following general guidelines when mounting this product.

- Before deciding on a location for the product, make sure there is easy access to the product for maintenance and programming purposes.
- Make sure that the structure onto which you are mounting the product can support the product's weight. See the [Technical Specifications](#) for weight information.
- When mounting the product overhead, always use a safety cable. Mount the product securely to a rigging point, whether an elevated platform or a truss.
- When rigging the product onto a truss, use a mounting clamp of appropriate weight capacity.
- When power linking multiple products, mount the products close enough for power linking cables to reach.
- The bracket adjustment knobs allow for directional adjustment when aiming the product to the desired angle. Only loosen or tighten the bracket knobs manually. Using tools could damage the knobs.

Procedure

The COLORdash Par-H12 IP comes with a double-bracketed yoke to which you can either attach mounting clamps for hanging or simply use as a floor stand. You must supply the mounting clamps. Make sure the clamps are capable of supporting the weight of this product. Use at least one mounting point per product. For the CHAUVET Professional line of mounting clamps, go to <http://www.trusst.com/products>.

Mounting Diagram

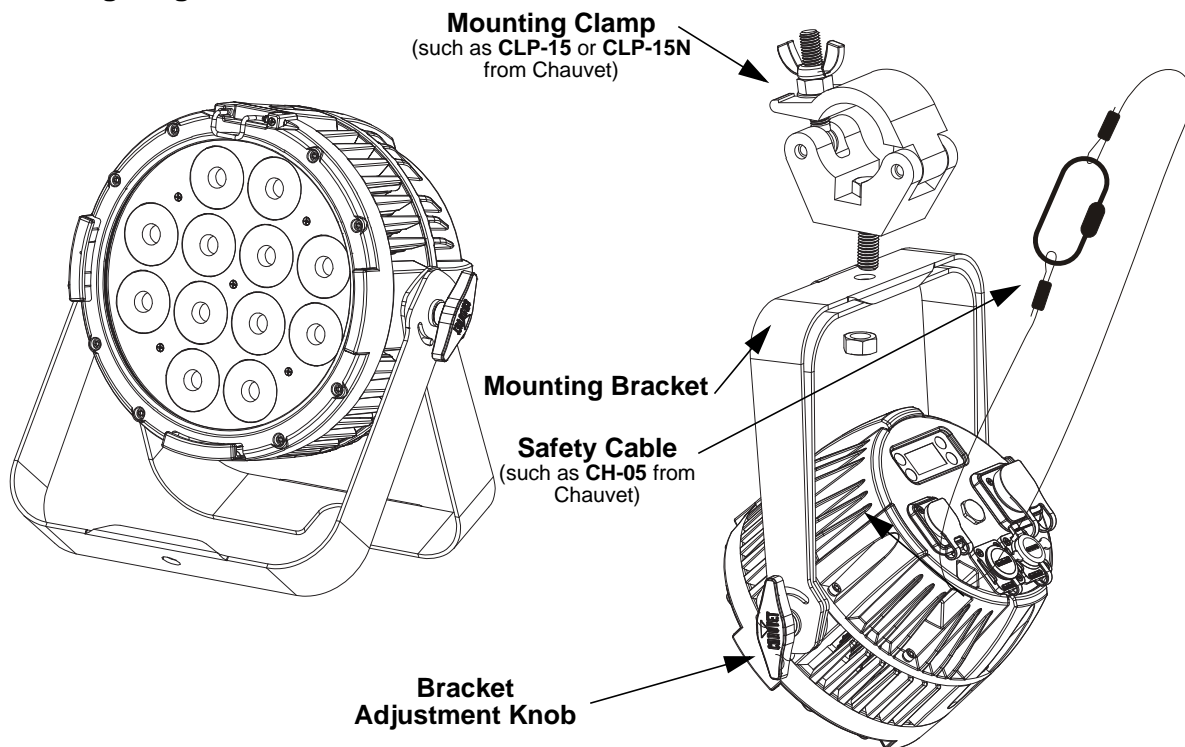

4. OPERATION

Control Panel Operation

Button	Function
<MENU>	Exits from the current menu or function
<ENTER>	Enables the currently displayed menu or sets the currently selected value in to the current function
<UP>	Navigates upward through the menu list or increases the numeric value when in a function
<DOWN>	Navigates downward through the menu list or decreases the numeric value when in a function

Control Options

Set the COLORdash Par-H12 IP starting address in the 001-512 DMX range. This enables control of up to 46 products in the 11-channel 11CH personality.

Programming

Refer to the Menu Map to understand the menu options. The menu map shows the main level and a variable number of programming levels for each option.

- To go to the desired main level, press <MENU> repeatedly until the option shows on the display. Press <ENTER> to select. This will take you to the first programming level for that option.
- To select an option or value within the current programming level, press <UP> or <DOWN> until the option shows on the display. Press <ENTER> to select. In this case, if there is another programming level, you will see that first option, or you will see the selected value.
- Press <MENU> repeatedly to exit to the previous main level.

Control Panel Lock

This setting enables you to activate or disable the control panel lock, which keeps unauthorized users from changing the product's settings.

1. Go to the **Key Lock** main level.
2. Select **On** or **Off**.



When the control panel lock is activated, in order to access the products main programming level, the product will prompt for the passcode. Enter the passcode as described below.

Passcode

After being prompted to enter the passcode:

Press <UP>, <DOWN>, <UP>, <DOWN>, <ENTER>

Menu Map

Main Level	Programming Levels		Description
DMX Address	001–512		Selects DMX address (highest channel restricted to personality chosen)
DMX Channel	6 CH		6-channel: RGBAWP control
	8 CH		8-channel: RGBAWP control, dimmer, and strobe
	13CH		13-channel: RGBWAP control, dimmer, strobe, color macro/white balance, white temperature, auto programs, auto speed, dimmer speed
Static	Fixed Color	R	Red
		G	Green
		B	Blue
		A	Amber
		W	White
		P	Ultraviolet (UV)
		RG	Red/Green
		RB	Red/Blue
		RA	Red/Amber
		RW	Red/White
		RP	Red/UV
		GB	Green/Blue
		GA	Green/Amber
		GW	Green/White
		GP	Green/UV
		BA	Blue/Amber
		BW	Blue/White
		BP	Blue/UV
		AW	Amber/White
		AP	Amber/UV
		WP	White/UV
		RGB	Red/Green/Blue
		RGA	Red/Green/Amber
		RGW	Red/Green/White
		RGP	Red/Green/UV
		RBA	Red/Blue/Amber
		RBW	Red/Blue/White
		RBP	Red/Blue/UV
		RAW	Red/Amber/White
		RAP	Red/Amber/UV
		RWP	Red/White/UV
		GBA	Green/Blue/Amber
GBW	Green/Blue/White		
GBP	Green/Blue/UV		
GAW	Green/Amber/White		
GAP	Green/Amber/UV		
GWP	Green/White/UV		
BAW	Blue/Amber/White		
BAP	Blue/Amber/UV		
BWP	Blue/White/UV		
AWP	Amber/White/UV		

Main Level	Programming Levels		Description	
Static	Fixed Color	RGBA	Red/Green/Blue/Amber	
		RGBW	Red/Green/Blue/White	
		RGBP	Red/Green/Blue/UV	
		RGAW	Red/Green/Amber/White	
		RGAP	Red/Green/Amber/UV	
		RGWP	Red/Green/White/UV	
		RBAW	Red/Blue/Amber/White	
		RBAP	Red/Blue/Amber/UV	
		RBWP	Red/Blue/White/UV	
		RAWP	Red/Amber/White/UV	
		GBAW	Green/Blue/Amber/White	
		GBAP	Green/Blue/Amber/UV	
		GBWP	Green/Blue/White/UV	
		GAWP	Green/Amber/White/UV	
		BAWP	Blue/Amber/White/UV	
		RGBAW	Red/Green/Blue/Amber/White	
		RGBAP	Red/Green/Blue/Amber/UV	
		RGBWP	Red/Green/Blue/White/UV	
		RGAWP	Red/Green/Amber/White/UV	
		RBAWP	Red/Blue/Amber/White/UV	
	GBAWP	Green/Blue/Amber/White/UV		
	RGBAWP	Red/Green/Blue/Amber/White/UV		
	Color Temperature	Warm White 1	0-255	Preset white color temperatures
		Warm White 2		
		Warm White 3		
		Neutral White 1		
		Neutral White 2		
Neutral White 3				
Daylight 1				
Daylight 2				
Daylight3				
Moving Head White				
Manual Color Mixer	Red	0-255	Combine red, green, blue, amber, white, and ultraviolet to make a custom color (0–100%)	
	Green			
	Blue			
	Amber			
	White			
UV				
Auto Show	Auto 1-5	1-100	Automatic programs	
Master/Slave Mode	Master		DMX mode (Master)	
	Slave		Slave mode	
Dimmer Mode	Off		No dimmer	
	Dimmer 1–3		Dimming curves Dimmer 1 (fast) to Dimmer 3 (slow)	
White Balance	Off		Uses factory default white setting	
	Manual	Red	125-255	Sets red LED maximum value
		Green		Sets green LED maximum value
		Blue		Sets blue LED maximum value
		Amber		Sets amber LED maximum value
		White		Sets white LED maximum value
UV	Sets UV LED maximum value			

Main Level	Programming Levels	Description
LED Frequency	600Hz	Selects the PWM output frequency
	1200Hz	
	2000Hz	
	4000Hz	
	6000Hz	
	25kHz	
Back Light	On	Display backlight always on
	10S	Turns off display backlight after 10 sec of inactivity
	20S	Turns off display backlight after 20 sec of inactivity
	30S	Turns off display backlight after 30 sec of inactivity
Key Lock	On	Turns the passcode on or off
	Off	
Information	Fixture Hours	Shows total product hours
	Version	Shows installed software version
	UID	Shows product UID
	Battery	Shows battery level
Reset Factory	No	Reset all settings to factory defaults
	Yes	

Configuration (DMX)

Use DMX configurations to operate the product with a DMX controller.

DMX Personalities

This setting allows you to choose a particular DMX personality.

1. Go to the **DMX Channel** main level.
2. Select the desired personality (**6 Ch**, **8 Ch**, or **13Ch**).



- See the [DMX Control](#) section for the highest starting address you can select for each personality.
- Make sure that the starting addresses on the various products do not overlap due to the new personality setting.

DMX Control

In this mode, each product will respond to a unique starting address from the DMX controller. All products with the same starting address will respond in unison.

1. Select a DMX personality as shown in [DMX Personalities](#).
2. Set the starting address:
 - a. Go to **DMX Address** main level.
 - b. Select the starting address (**001–512**).

The highest recommended starting address for each DMX mode is as follows:

DMX Personality	DMX Address
13	500
8	505
6	507

DMX Values

13Ch

Channel	Function	Value	Percent/Setting
1	Dimmer	000 ⇄ 255	0-100%
2	Red	000 ⇄ 255	0-100%
3	Green	000 ⇄ 255	0-100%
4	Blue	000 ⇄ 255	0-100%
5	Amber	000 ⇄ 255	0-100%
6	White	000 ⇄ 255	0-100%
7	Purple (UV)	000 ⇄ 255	0-100%
8	Strobe	000 ⇄ 010 011 ⇄ 255	No function Slow to fast
9	Color Macro + White Balance	000 ⇄ 010 011 ⇄ 030 031 ⇄ 050 051 ⇄ 070 071 ⇄ 090 091 ⇄ 110 111 ⇄ 130 131 ⇄ 150 151 ⇄ 170 171 ⇄ 200 201 ⇄ 205 206 ⇄ 210 211 ⇄ 215 216 ⇄ 220 221 ⇄ 225 226 ⇄ 230 231 ⇄ 235 236 ⇄ 240 241 ⇄ 245 246 ⇄ 250 251 ⇄ 255	No function R:100% G: 0-100% B: 0 R:100%-0 G: 100% B: 0 R:0 G: 100% B: 0-100% R:0 G: 100%-0 B: 100% R:0-100% G: 0 B: 100% R:100% G: 0 B: 100%-0 R:100% G: 0-100% B: 0-100% R:100%-0 G: 100%-0 B: 100% RGB: 100% White 1 White 2 White 3 White 4 White 5 White 6 White 7 White 8 White 9 White 10 White 11
10	Color Temperature	000 ⇄ 005 006 ⇄ 025 026 ⇄ 050 051 ⇄ 075 076 ⇄ 100 101 ⇄ 125 126 ⇄ 150 151 ⇄ 175 176 ⇄ 200 201 ⇄ 225 226 ⇄ 250 251 ⇄ 255	No function Warm White 1 Warm White 2 Warm White 3 Neutral White 1 Neutral White 2 Neutral White 3 Daylight 1 Daylight 2 Daylight 3 Moving Head White No function
11	Auto Programs	000 ⇄ 010 011 ⇄ 060 061 ⇄ 110 111 ⇄ 160 161 ⇄ 210 211 ⇄ 255	No function Auto program 1 Auto program 2 Auto program 3 Auto program 4 Auto program 5
12	Auto Speed	000 ⇄ 255	0-100%
13	Dimmer Speed	000 ⇄ 051 052 ⇄ 101 102 ⇄ 152 153 ⇄ 203 204 ⇄ 255	Preset dimmer speed from display menu Linear dimmer Nonlinear dimming curve 1 (fastest) Nonlinear dimming curve 2 Nonlinear dimming curve 3 (slowest)

8 Ch

Channel	Function	Value	Percent/Setting
1	Dimmer	000 ⇄ 255	0-100%
2	Red	000 ⇄ 255	0-100%
3	Green	000 ⇄ 255	0-100%
4	Blue	000 ⇄ 255	0-100%
5	Amber	000 ⇄ 255	0-100%
6	White	000 ⇄ 255	0-100%
7	Purple (UV)	000 ⇄ 255	0-100%
8	Strobe	000 ⇄ 010 011 ⇄ 255	No function Slow to fast

6 Ch

Channel	Function	Value	Percent/Setting
1	Red	000 ⇄ 255	0-100%
2	Green	000 ⇄ 255	0-100%
3	Blue	000 ⇄ 255	0-100%
4	Amber	000 ⇄ 255	0-100%
5	White	000 ⇄ 255	0-100%
6	Purple (UV)	000 ⇄ 255	0-100%

Configuration (Standalone)

Use standalone configuration to operate the product without a DMX controller.

Auto Programs

Auto programs allow for dynamic RGBA color mixing without a DMX controller.

1. Go to the **Auto Show** main level
2. Select the desired auto (**Auto 1-5**)
3. Select the desired speed (**Speed 0-100**)



The auto programs cannot be edited.

Master/Slave

The Master/Slave mode allows a group of COLORdash Par-H12 IP products (the slaves) to simultaneously duplicate the output of another COLORdash Par-H12 IP (the master) without a DMX controller.

To set each of the slaves:

1. Go to the **Master/Slave Mode** main level
2. Select **Slave**

To set the master:

1. Go to the **Master/Slave Mode** main level
2. Select **Master**
3. Select an auto program as explained in Auto Programs, or a static mix of colors.



- The master is the one that runs a program whether in Auto, or Static Color mode.
- Do not connect a DMX controller to the products configured for Master/Slave operation. The DMX controller may interfere with signals from the master.
- The master should be the first product in the daisy chain.

White Balance

This setting allows for selection of the white balance shown by the COLORdash Par-H12 IP when **Static > Manual Color Mixing > Red, Green, Blue, Amber, White, and UV**. or the DMX controller's Red, Green, Blue, Amber, White, and UV faders are set to **255**.

1. Go to the **White Balance** main level.
2. Select **Manual** to continue to adjust the white balance or **Off** to default to the original factory setting.
3. Select a color (**Red, Green, Blue, Amber, White, or UV**).
4. Select a color value (**125–255**).
5. Repeat for the other colors.



The values of **Red, Green, Blue, Amber, White, and UV** configured will define the color temperature shown when the **RGBAW+UV** faders are set to **255**.

Static Fixed Color

The Static Fixed Color mode allows for permanent RGBAW+UV presets without a DMX controller.

1. Go to the **Static** main level.
2. Select **Fixed Color**.
3. Select the desired color combination (See [Menu Map](#) for list of color combination options).

Static Manual Color

The Static Manual Color mode allows for permanent RGBA color mixing without a DMX controller.

1. Go to the **Static** main level.
2. Select **Manual Color Mixer**.
3. Select the desired color (**Red, Green, Blue, Amber, White, or UV**).
4. Select the color value (**000–255**).
5. Repeat for the other colors.

Color Temperature

The color temperature mode allows for permanent white color temperature presets without a DMX controller.

1. Go to the **Static** main level.
2. Select **Color Temperature**.
3. Select the desired color (**Warm White 1, Warm White 2, Warm White 3, Neutral White 1, Neutral White 2, Neutral White 3, Daylight 1, Daylight 2, Daylight 3, or Moving Head White**).

Dimmer Profiles

This setting determines how fast the output of the COLORdash Par-H12 IP changes when you modify the values of the red, green, blue, amber, and dimmer faders. This setting provides four different options to simulate the dimming curve of an incandescent lighting product.

- Go to the **Dimmer Mode** main level.
- Select a dimmer curve (**OFF, Dimmer 1, Dimmer 2, or Dimmer 3**).



OFF: The output is proportional (linear) to the dimmer and RGBAW+UV channel values.

Dimmer 1-3: The output follows the dimmer and RGBAW+UV channel values based on the corresponding dimmer curve, **DIM1** being the fastest.

LED Frequency

This option changes the Pulse Width Modulation (PWM) frequency of the LEDs on the COLORdash Par-H12 IP.

1. Go to the **LED Frequency** main level.
2. Select PWM Frequency (**600Hz, 1200Hz, 2000Hz, 4000Hz, 6000Hz, or 25Khz**).

Back Light

This setting allows for selection of the amount of time the backlight on the COLORdash Par-H12 IP's display stays on after the last button is pressed on the control panel.

1. Go to the **Back Light** main level.
2. Select **On** (remains on), **10S** (10 seconds), **20S** (20 seconds), or **30S** (seconds).

Fixture Hours/Software Version

This option displays the total number of hours the product has run, the UID (Universal Identification) code, the battery level and the installed software version.

1. Go to the **Information** main level.
2. Press <ENTER> to view.

Factory Reset

This option resets all product settings to the original factory setting.

1. Go to the **Factory Reset** main level.
2. Select **Yes**.

5. TECHNICAL INFORMATION

Product Maintenance

To maintain optimum performance and minimize wear, clean this product frequently. Usage and environment are contributing factors in determining the cleaning frequency.

Clean this product at least twice a month. Dust build-up reduces light output performance and can cause overheating. This can lead to reduced light source life and increased mechanical wear.

To clean the product:

1. Unplug the product from power.
2. Wait until the product is at room temperature.
3. Use a vacuum (or dry compressed air) and a soft brush to remove dust collected on the external vents.
4. Clean all transparent surfaces with a mild soap solution, ammonia-free glass cleaner, or isopropyl alcohol.
5. Apply the solution directly to a soft, lint free cotton cloth or a lens cleaning tissue.
6. Softly drag any dirt or grime to the outside of the transparent surface.
7. Gently polish the transparent surfaces until they are free of haze and lint.



Always dry the transparent surfaces carefully after cleaning them.

6. TECHNICAL SPECIFICATIONS

Dimensions and Weight

Length	Width	Height	Weight
12.3 in (322 mm)	11.9 in (305 mm)	6.9 in (177 mm)	13.4 lb (6.1 kg)

Note: Dimensions in inches rounded to the nearest hundredth.

Power

Power Supply Type	Range	Voltage Selection
Switching (internal)	100 to 240 VAC, 50/60 Hz	Auto-ranging

Parameter	120 V, 60 Hz	230 V, 50 Hz
Consumption	113 W	117 W
Operating Current	0.936 A	0.505 A
Power linking current (products)	13.6 A (14 products)	13.6 A (26 products)

Power I/O	U.S./Canada	Worldwide
Power input connector	Seetronic Powerkon IP65	Seetronic Powerkon IP65
Power output connector	Seetronic Powerkon IP65	Seetronic Powerkon IP65
Power Cord plug	Edison (U.S.)	Local Plug

Light Source

Type	Power	Lifespan
LED	8.6 W	50,000 hours

Color	Quantity	Current
hex-color RGBAW+UV	12	632 mA

Photometrics

Parameter	Value
Strobe Rate	0 to 30 Hz
Beam Angle	22°
Field Angle	34°
Illuminance @ 2 m	1180 lux

Thermal

Maximum External Temperature	Cooling System
113 °F (45 °C)	Convection

DMX

I/O Connector	Channel Range
5-pin XLR	6, 8 or 13

Ordering

Product Name	Item Code	UPC Number
COLORdash Par-H12 IP	03031297	781462216450



UL 1573
CSA C22.2 No. 166
E113093



RETURNS

Send the product prepaid, in the original box, and with the original packing and accessories. Chauvet will not issue call tags.

Call Chauvet and request a Return Merchandise Authorization (RMA) number before shipping the product. Be prepared to provide the model number, serial number, and a brief description of the cause(s) for the return.

Clearly label the package with an RMA number. Chauvet will refuse any product returned without an RMA number.



Write the RMA number on a properly affixed label. DO NOT write the RMA number directly on the box.

Once you have the RMA number, provide the following information on a piece of paper and place it inside the box:

- Your name
- Your address
- Your phone number
- RMA number
- A brief description of the problem

Be sure to pack the product properly. Any shipping damage resulting from inadequate packaging will be your responsibility. FedEx packing or double-boxing are recommended.



Chauvet reserves the right to use its own discretion to repair or replace returned product(s).

CONTACT US

World Headquarters	
General Information	Technical Support
Address: 5200 NW 108th Ave. Sunrise, FL 33351 Voice: (954) 577-4455 Fax: (954) 929-5560 Toll Free: (800) 762-1084	Voice: (844) 393-7575 Fax: (954) 756-8015 Email: chauvetcs@chauvetlighting.com
	Website
	www.chauvetlighting.com
EUROPE	
General Information	Technical Support
Address: Stokstraat 18 9770 Kruishoutem Belgium Voice: +32 9 388 93 97	Email: eutech@chauvetlighting.eu
	Website
	www.chauvetlighting.eu
General Information	Technical Support
Address: Unit 1C Brookhill Road Industrial Estate Pinxton, Nottingham, UK NG16 6NT Voice: +44 (0) 1773 511115 Fax: +44 (0) 1773 511110	Email: uktech@chauvetlighting.com
	Website
	www.chauvetlighting.co.uk
MEXICO	
General Information	Technical Support
Address: Av. de las Partidas 34 - 3B, Zona Industrial Lerma Lerma, Edo. de México, CP 52000 Voice: +52 (728) 285-5000	Email: servicio@chauvet.com.mx
	Website
	www.chauvet.com.mx

Visit the applicable website above to verify our contact information and instructions to request support. Outside the U.S., United Kingdom, Ireland, Mexico or Benelux, contact the dealer of record.