

USER MANUAL

RevA 06-2013

LPA SERIES

DIGITALLY CONTROLLED
LINEAR AUDIO POWER AMPLIFIER

Welcome

Thank you for choosing Hill Audio for your sound system. To make sure that this product meets your expectations and provides long-term, reliable performance, please read and follow this instruction manual carefully.

Manual Language

UK	This user manual is written in English. For other languages, visit	www.hill-audio.com
FR	Ce guide est écrit en anglais. Pour les autres langues, visitez:	www.hill-audio.com
DE	Diese Anleitung ist in Englisch verfasst. Für andere Sprachen:	www.hill-audio.com
ES	Este manual está escrito en Inglés. Para otros idiomas, visite:	www.hill-audio.com
PT	Este manual está escrito em Inglês. Para outros idiomas, visite:	www.hill-audio.com
IT	Questo manuale è scritto in inglese. Per altre lingue, visitare:	www.hill-audio.com

Important safety instructions

- Read these instructions and all markings on the product. Keep these instructions.
- Heed all warnings and instructions, both in this manual and on the product.
- Clean only with a dry cloth. Unplug from AC supply before cleaning.
- Do not use this product near water and avoid any exposure to water.
- Before connecting this product to any AC supply, make sure to check whether the AC mains voltage and frequency match the indication on the product and its packaging.
- Only connect this product to an AC supply with sufficient power handling, protective earth connection, ground-fault (earth-fault) protection and overload protection.
- Disconnect the product from the AC supply during thunderstorms or longer periods of being unused.
- Make sure any heat sink or other cooling surface, or any air convection slot, is exposed sufficiently to free air circulation and is not blocked.
- Do not operate this product in environmental temperatures exceeding 35 degrees Celsius and/or 85% relative humidity.
- Position the product in a safe and stable place for operation, out of reach of unauthorized persons.
- Make sure any cable connections to and from the product are neither subject to potentially destructive mechanical impact nor present any risk of stumbling or other accident risk to people.
- Audio equipment may generate sound pressure levels sufficient to cause permanent hearing damage to persons. Always start up at low volume settings and avoid prolonged exposure to sound pressure levels exceeding 90 dB.
- Do not open this product for service purposes. There are no user-serviceable parts inside. Warranty will be void in any case of unauthorized service by the user or other not authorized persons.
- Take any precaution required by local law, applicable regulations or good business practice to avoid injury of people or material damage by use of this product.

Explanation of symbols used in this manual and on the product:



ATTENTION!
Read manual before installation and operation.



DANGER!
Safety hazard.
Risk of injury or death.



WARNING!
Hazardous voltage.
Risk of severe or fatal electric shock.



WARNING!
Fire hazard.

Description

The LPA series is a range of audio power amplifiers using bipolar power devices which are - depending on the model, respectively the power - supplied by a single voltage linear power supply (class AB) or a dual-voltage linear power supply (class H, or more precisely class G). The LPA series comes with full microprocessor control of all protection functions (short-circuit, DC, overheat) and Hill Audio's innovative PowerEdge™ limiter which adjusts the input limiter threshold automatically based on the available AC supply voltage. This allows distortion-free maximum power at any AC supply condition. Using proven linear power supply technology, the LPA series is simple to operate and excels in any application where low weight is not mandatory, but consistent performance with high reliability is required. All status indications can easily be obtained from the large multi-color front-panel LCD display, which is also visible from larger distances. The combination of its features and characteristics makes the LPA series a perfect choice for any installed sound system.

Health advice

This unit produces and absorbs electromagnetic radiation. The strength of radiation and the sensitivity for disturbing interference matches the CE and FCC requirements. A corresponding sign is printed on the backside of the unit. Any change or modification may affect the behavior of the unit concerning electromagnetic radiation, with the CE requirements eventually not to be met any more. The manufacturer takes no responsibility in this case.

Functional advice

This unit is immune to the presence of electromagnetic disturbances – both conducted and radiated - up to a certain level. Under peak conditions, the unit is classified to show a “class C” performance criteria and may encounter temporary degradation or loss of function which may need manual help to recover. In such case, disconnect the AC power from the unit and reconnect it again to recover.

Environmental advice

This unit is built to conform to the ROHS standards and the WEEE directive 2002/96/EC of the European Parliament and of the Council of the European Union. Under these regulations, the product shall not be discarded into regular garbage at the end of its life, but shall be returned to authorized recycling stations.

Unpacking

Please check that the box contains the following items:

Main parts: 1 pc. LPA amplifier main unit
 1 pc. Mains cable (only for models with IEC input)
 1 pc. Operation manual

If any part is missing, please contact your dealer immediately for replacement.

Warning



After unpacking, and before plugging the AC cord in the wall outlet, check whether the AC mains voltage and frequency is the same as this product is specified for (see rear panel of product). Whenever the specified voltage or your AC plug should not match the local conditions, do NOT plug the AC cord into the wall outlet and contact your dealer immediately.

Controls and Connections

Connections - Rear (Models LPA500 & LPA 800)

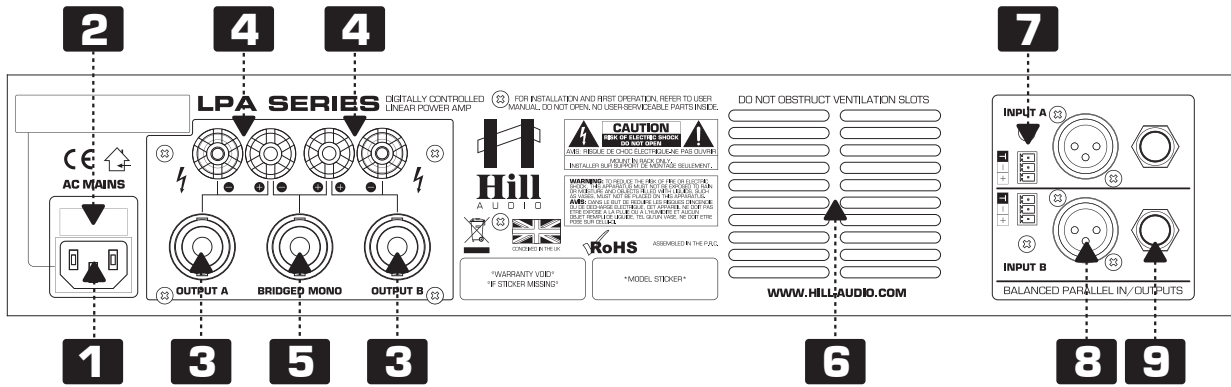

Connections - Rear (Models LPA1400, LPA 1800, LPA2400, LPA3000)

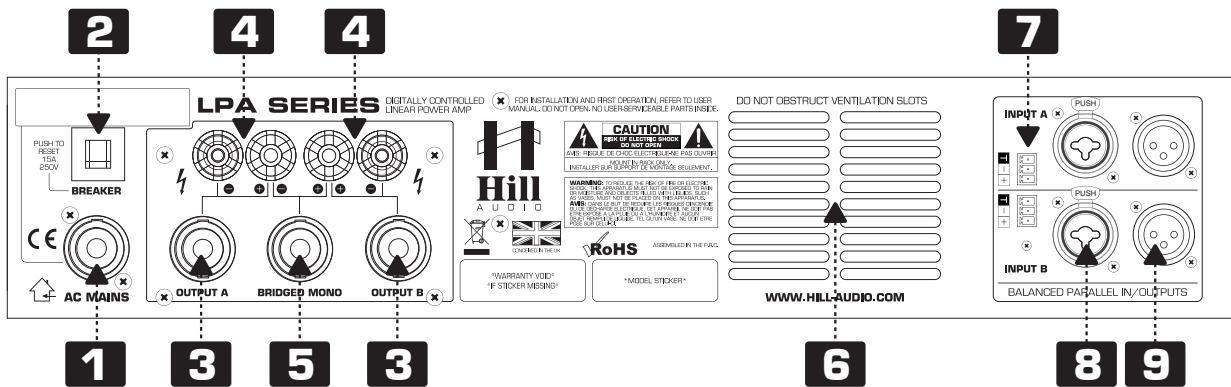

Controls - Front

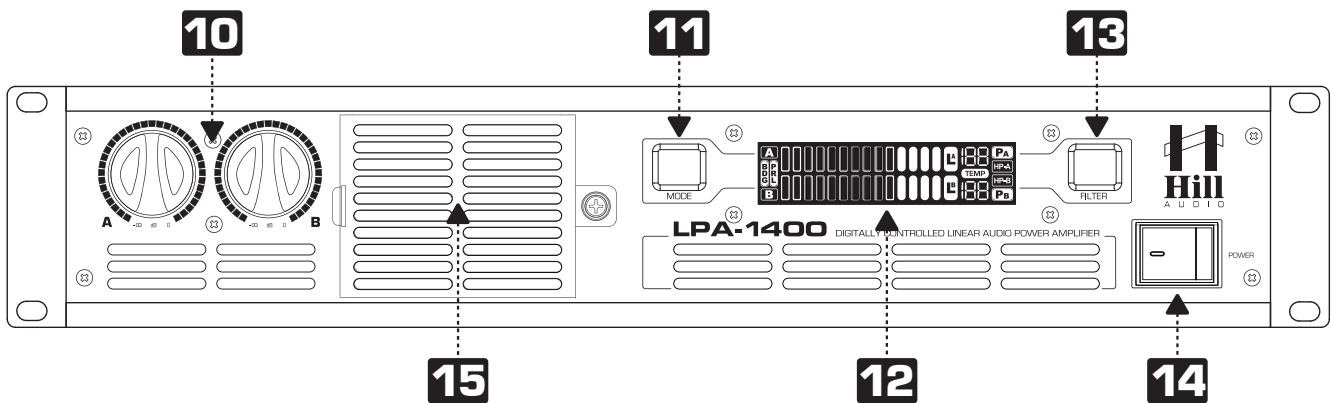

Display - Front

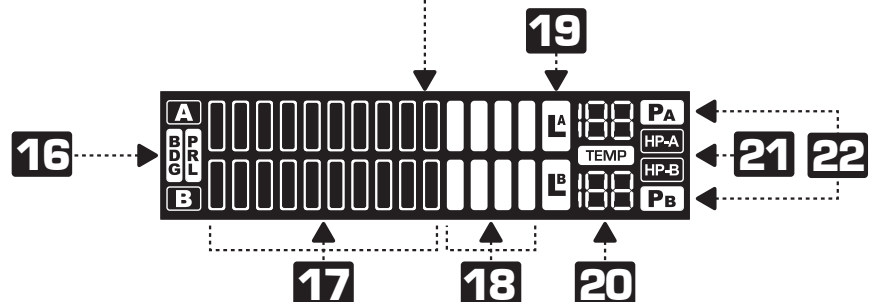

Functional Description

The LPA series is an analog audio power amplifier with two channels, which can be used with independent input signals (stereo mode), identical input signal (parallel mode) or in bridge mode as a single channel amplifier. It displays all relevant status information on a 3-color front-panel display and offers a multitude of input and output connections for great application versatility.

- 1** AC inlet. Depending on the version, this may be an IEC power inlet or a PowerCon™-compatible power inlet. For versions with IEC inlets, use the supplied AC cord to connect the unit to AC mains. For versions with PowerCon™-compatible power inlet, use a cable equipped with a PowerCon™ compatible plug. Make sure voltage and frequency stated and set on the unit comply with your local AC supply.
- 2** Fuse holder | Circuit breaker. Depending on the version, the AC mains fuse is either a cartridge type located in a small drawer close to the AC inlet (for IEC inlet versions) or a resettable breaker type located above the AC inlet for versions with PowerCon™-compatible inlets. To change a cartridge type fuse, unplug the AC cord first, pull out the fuse drawer and replace the fuse ONLY with a fuse of SAME voltage and rating. To reset a tripped circuit breaker type fuse, simply switch the fuse back to ON status. If the fuse blows again after replacement, hand over the unit to qualified service personnel.
- 3** Speakon™-compatible speaker outputs for stereo and parallel mode operation (see explanation in chapter “setting the operation mode”). Connect your speaker leads with matching connectors here. Alternatively, speakers can be connected to the two black+red binding post speaker outputs (4). Do not connect speakers to both these Speakon™-compatible outputs and the binding post outputs (4) or the bridge output (5) at the same time.
- 4** Binding post speaker outputs for stereo, parallel and bridge mode operation (see explanation in chapter “setting the operation mode”). Connect your speaker leads here, using one pair of red and black posts each to connect leads to speakers A and B respectively if you use stereo and parallel mode, and use both red posts to connect leads to your speaker for bridge mode operation. Alternatively, speakers can be connected to the Speakon™-compatible outputs (3) for stereo or parallel mode operation and to the Speakon™-compatible outputs (5) for bridge mode operation. Do not connect speakers to both these binding post outputs and the Speakon™-compatible outputs (3, 5) at the same time.
- 5** Speakon™-compatible speaker output for bridge mode operation (see explanation in chapter “setting the operation mode”). Connect your speaker lead with matching connector here. Alternatively, the speaker can be connected to the two red binding post speaker outputs (4). Do not connect speakers to this Speakon™-compatible output and the binding post outputs (4) or the Speakon™-compatible speaker outputs (3) at the same time.
- 6** Fan ventilation slots. The amplifier pushes the cooling air out of these slots. Make sure these slots remained unobstructed. For more information about cooling, see the chapter “Installation, Cooling and Wiring”.
- 7** Channel signal inputs. These are a balanced terminal blocks designed to accept matching connectors which carry input signals for channels A and B respectively. Channel B input remains unused in parallel and bridge operation modes (see explanation of operation modes in chapter “setting the operation mode”). Alternatively, use inputs (8) to connect input sources. Do not connect input sources to these connectors and the inputs (8) at the same time.
- 8** Channel signal inputs. These are - depending on version - balanced female XLR or Combo (XLR+TRS) connectors for input signals to channels A and B respectively. Channel B input remains unused in parallel and bridge operation modes (see explanation of operation modes in chapter “setting the operation mode”). Alternatively, use inputs (7) to connect input sources. Do not connect input sources to these connectors and the inputs (7) at the same time.

- 9** Channel signal outputs. These are - depending on version - balanced TRS or male XLR connectors. The signal presented to the inputs (7) or (8) is available here. No buffering or conditioning is applied to the input signal; the outputs (9) are simply in parallel to the inputs (7) and (8).
- 10** Channel volume controls. Depending on the chosen operation mode (see explanation of operation modes in chapter “setting the operation mode”), these 41-click precision potentiometers control either both channel volumes individually (in stereo and parallel modes) or channel A volume control is active while channel B volume control is disabled (in bridge mode).
- 11** Mode selector switch. Selects the operation mode (see explanation of operation modes in chapter “setting the operation mode”). Repeatedly pressing this button toggles through the three possible operation modes STEREO - PARALLEL - BRIDGE. The mode indicator (16) in the display (12) will indicate the set mode of operation (all indicators off = STEREO, PRL indicator on = PARALLEL, BDG indicator on = BRIDGE).
- 12** Display. See details below.
- 13** Filter selector switch. Selects whether a 40Hz/18dB-slope highpass-filter is applied to the relative input. Repeatedly pressing this button toggles through the four possible settings:
[a] no high-pass filter applied to any of the two inputs: display indicators (21) both off
[b] highpass-filter applied only to channel A: “HP-A” indicator (21) on
[c] highpass-filter applied only to channel B: “HP-B” indicator (21) on
[d] highpass filters applied to both channels A and B: “HP-A” and “HP-B” indicators (21) both on.
- 14** Power switch. Switches the unit on and off. Note that in a sound system, the amplifier shall be the last unit to be switched on during powering up, and the first to be switched off during powering down. Always turn the volume control (10) down before switching on, or make sure that any signal source connected to the amplifier is turned down before switching on.
- 15** Cooling air inlet. This is the main inlet for cooling air, covered with a filter frame which holds an exchangeable filter sponge. Note that the air flow is from front to rear. See chapter “Installation, Cooling and Wiring” for further details.

Display Elements

- 16** Mode Indicators. Indicate the set mode of operation (all indicators off = STEREO, PRL indicator on = PARALLEL, BDG indicator on = BRIDGE). Toggle between these settings via the button (11).
- 17** Level Meter (Area \leq 0dB). Displays the signal level in the lower level range.
- 18** Level Meter (Area $>$ 0dB). Displays the signal level in the upper level range. Make sure to set the volume controls (10) in a way that the upper level range is only entered when the signal peaks. Level controls (10) shall be set in a way that none of the upper level range indicators is on all the time.
- 19** Limiter Indicators. If output levels increase beyond low-distortion power handling capabilities of the amplifier, a limiter is engaged to avoid any further increase of the output level. Such occurrence is displayed by these indicators. Reduce the volume control (10) setting until the limiter indicators do not light up anymore.
- 20** Temperature display. Shows the heatsink temperature individually for each channel. Exceeding 100 degrees will engage the temperature protection. If at any time the displayed temperature approached 100 degrees and keeps rising, either improve cooling or reduce the volume control settings until the temperature stabilizes at a safe value.

21 High pass filter status indicator. Displays the chosen high pass filter setting:
 [a] no high-pass filter applied to any of the two inputs: display indicators (21) both off
 [b] highpass-filter applied only to channel A: “HP-A” indicator (21) on
 [c] highpass-filter applied only to channel B: “HP-B” indicator (21) on
 [d] highpass filters applied to both channels A and B: “HP-A” and “HP-B” indicators (21) both on.
 Use button (13) to toggle between these settings.

22 Protection status indicator. These are two individual protection status indicators for channel A and B, which light up when the protection circuit for any of the two channels engages. This may happen if DC is detected on a channel’s output, if a channel’s output is exposed to a short circuit or if the temperature of the amplifier exceeds safe levels. Temperature-triggered protection mode is auto-reset when the temperature has fallen back to safe levels; DC or short-circuit triggered protection mode requires the amplifier to be switched off and re-switched on in order to clear the protection status.

Setting the operation mode

Depending on the application, the LPA series amplifiers can be operated in STEREO, PARALLEL or BRIDGE mode. The mode is chosen by the button (11) with following options:

- STEREO mode: Both channels operate independently. Output A carries the amplified Input A signal, volume is set by the channel A volume control and the level is displayed by the channel A level meter of the display. Channel B operates in the same way. Display indicators (16) are off.
- PARALLEL mode: Input A is active, input B is disabled. Both speaker outputs (3) or (4) will carry the same signal of input A but can be individually set for their volume. The output level of each output is shown individually on the A and B display of the level meter. The display indicator (16) shows “PRL”.
- BRIDGE mode: Input A is active, input B is disabled. The bridge output (5) carries the output signal, for which the level is set by the Channel A volume control. The output level is displayed on the channel A level meter. The channel B volume control and the channel B level meter are disabled. The display indicator (16) shows “BDG”.

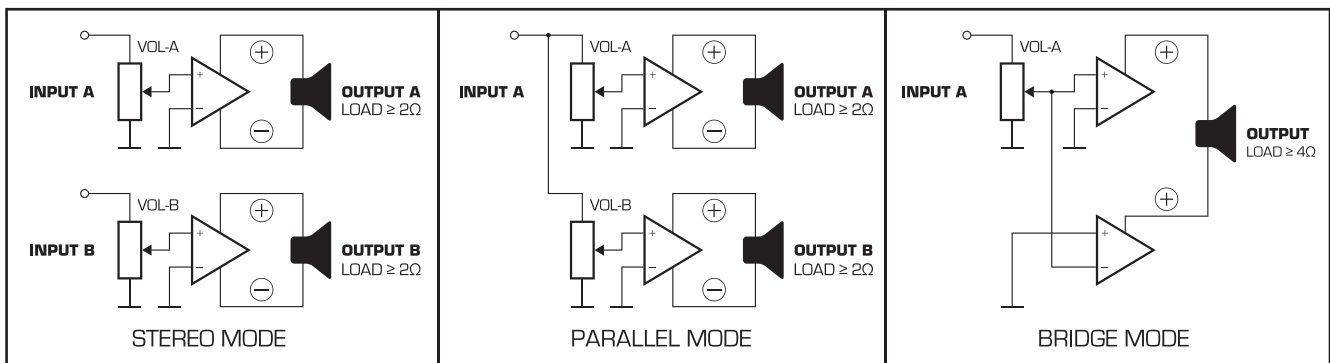

A note on speaker (load) impedances

In STEREO and PARALLEL mode, the minimum load impedance of the connected speaker(s) is 2 Ω, in BRIDGE mode 4 Ω. It is however recommended to operate the amplifier with 4 Ω minimum loads in STEREO and BRIDGE modes, and with 8 Ω minimum load in BRIDGE mode. While in theory low load impedances deliver a higher power yield, dynamic speakers do not have a flat impedance response, and many 4 Ohm speakers may have their impedance minimum at only half of the rated impedance at certain frequencies. This means a 4 Ω woofer may have an impedance of 2 Ohms or less at certain frequencies, and the attempt to run two such woofers in parallel in order to extract maximum power from the amplifier in “2 Ω” operation effectively means that the load impedance at certain frequencies will be only 1 Ω. This may cause excessive currents in the amplifier’s output stage, leading to higher heat generation, which may then trip the amplifier’s protection circuit either because of excessive heat or the detection of an output short circuit situation. For these reasons, 2 Ω loads are not recommended for stable and reliable operation of a sound system.

Installation, Cooling and Wiring

Rack Mounting

Due to the weight of the unit, rack mounting shall only be expedited in racks with additional rear mounting profiles and internal front-to-rear support shelf rails, in order to avoid the complete unit weight to be only held by the units' front rack ears. Mounting an amplifier into a rack without such support shelf rails may cause damage to both the rack and the amplifier.

Cooling

LPA amplifiers employ front-to-back cooling with fan-forced air flow (Fig. A). To achieve proper cooling, it is thus important that the front-side air inlet is unobstructed, same as the rear-side air outlet. Further, sufficient air circulation on the rear side of the amplifier is essential to avoid hot air congestion, which may lead to overheating.

In contained spaces like flight cases and racks, this requires to include air ventilation panels in the rack layout (Fig. B). Preferably, one 1U ventilation panel is placed on top of every amplifier.

From time to time, it is recommended to clean the front air filter. Unscrew the frame holder screw and remove the filter frame as shown in Fig C. Blow out dust from the filter and re-assemble in reverse sequence.

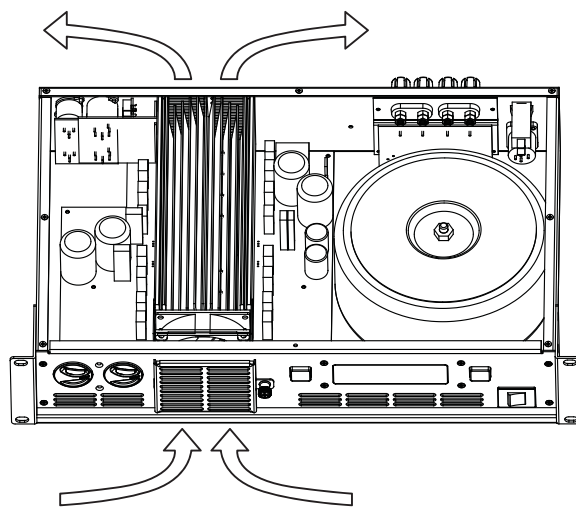

Fig. A: Internal air flow

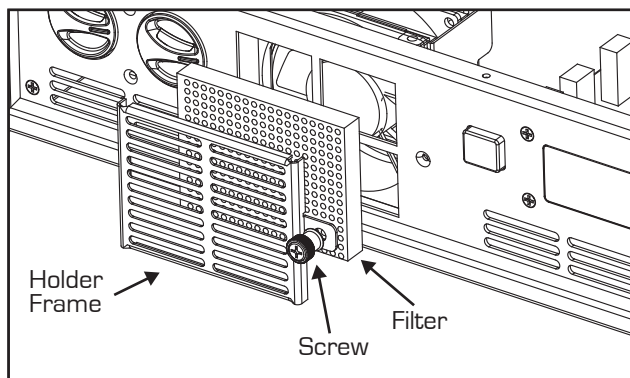

Fig. C: Cleaning the air filter

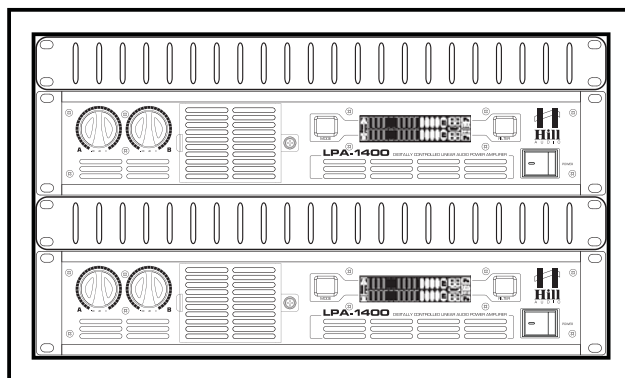

Fig. B: Rack arrangement

Speaker Cabling

Aside of proper signal cabling for the input signals (see chapter Operation - Connections), the choice of suitable speaker cables is often a neglected but at the same time essential point of amplifier installation. Speaker cables, specifically long ones, can significantly contribute to the load impedance of the amplifier, thus reducing the power output and turning some of the output power into heat instead of delivering it to the speakers. The most important aspect is to keep cables as short as possible and to choose a sufficient copper cross-section, with maximum length values as per below:

Cross-Section	AWG	2 Ohms	4 Ohms	6 Ohms	8 Ohms
0.75 mm ²	18	1.00 m	2.00 m	3.00 m	4.00 m
1.5 mm ²	15	2.00 m	4.00 m	6.00 m	8.00 m
2.5 mm ²	13	3.50 m	7.00 m	10.50 m	14.00 m
4.0 mm ²	11	5.00 m	10.00 m	15.00 m	20.00 m

Operation

A. Connections

For connecting this unit to AC mains, please note:

- Check whether the AC mains voltage and frequency is the same as this product is specified for (see rear panel of product). Whenever the specified voltage or your AC plug should not match the local conditions, do NOT plug the AC cord into the wall outlet and contact you dealer immediately.
- Do not operate this unit without the line cord earth ground connected. To do so may increase the risk of electric shock and increase line cord conducted emissions.

For making audio signal connections, always remember that good and reliable connections are a basic requirement for good sound and reliable operation. Bad soldering of cables can result in intermittent audio signals or temporarily lost ground connections, hence always use good cables. In case of doubt about making proper connections, please see check the standard pin assignments required for proper operation in the following section of this manual.

B. Powering up

Following a proper power-up sequence protects your equipment – specifically speakers – and your ears. Follow the below procedure:

- Turn down all output volume controls of any equipment in your audio system.
- Switch on your audio sources first (Tuners, CD Players, PC's with soundcards, Tapedecks, etc.)
- Switch on the audio mixer
- Switch on any audio processor between the mixer and the amplifier(s) [if any].
- Switch on the amplifier(s).
- Turn up the audio level on your sources if such controls are provided.
- Set the audio output of your mixer to a low level.
- Set the audio output of any audio processor between the mixer and the amplifier(s) to a medium level [if any such processors].
- Turn up the volume controls of your amplifier(s) slowly.
- Make adjustments to all volume settings as needed.

For switching off, follow the inverse sequence – always switch off your amplifier(s) first, then any processors between mixer and amplifier(s), then the mixer, then the sources.

C. Use

Apart from using good equipment, good sound comes from using it correctly. Level setting mistakes are one of the common reasons why even good equipment may not perform as desired. For setting levels, please be reminded that two guidelines need to be followed:

- Avoid distortion by leaving some headroom. Never overrun any audio-equipment's inputs. Level meters and displays allow you to make sure that signals do not enter critical levels.
- Avoid unnecessary amplification by using as little attenuation as possible. For example, if you turn down the input gain of a mixer to minimum, and then increase the main output of the mixer to maximum to drive your amplifier properly, you will create unnecessary noise, as you first dispose of some already existing signal level, and then later apply amplification [tainted with noise] to make it up.

Obviously, these two requirements are marking a levelling window that the operator must match to achieve a good sound with as little distortion and noise as possible.





WARNING - HEALTH RISK

Excessive volume levels on headphones or other sound systems may cause hearing damage. Always turn the volume control to minimum when you switch the unit on, and avoid prolonged exposure to sound pressure levels exceeding 90dB.

Connections

The LPA series amplifiers use the below connector types, for which the pin assignment must comply with the following specification. Always make sure to use good connectors and cables to ensure proper operation. Balanced signal connections are to be preferred over unbalanced connections where applicable and feasible. Avoid unbalanced signal connections exceeding 2m of cable length. For speaker cable considerations, see the “speaker cabling” chapter.

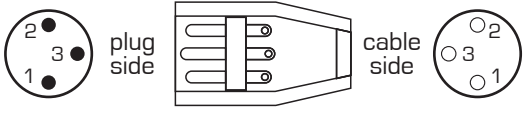
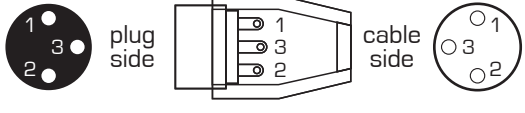
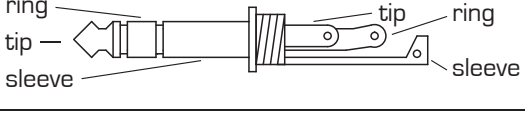
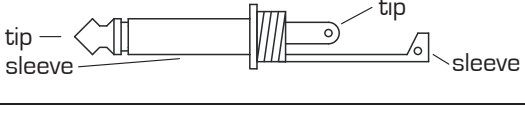
Signal Cables

	Structure	Balanced connection	Unbalanced connection
XLR male		red = 2 black = 3 shield = 1	red = 2 shield = 1+3
XLR female		red = 2 black = 3 shield = 1	red = 2 shield = 1+3
6.35mm TRS-stereo		red = tip black = ring shield = sleeve	red = tip shield = sleeve+ring
6.35mm TRS-mono		red = tip black = sleeve shield = uncon.	red = tip shield = sleeve
Terminal Plug		red = 1 black = 2 shield = 3	red = 1 shield = 2+3

CABLE Types

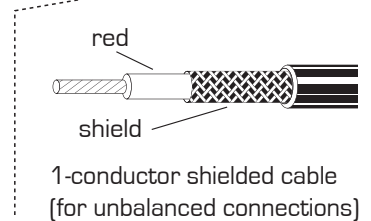
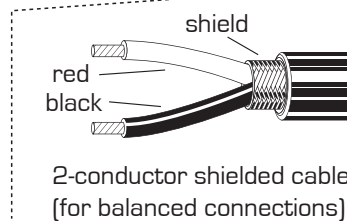

Speaker Cables

Speakon™ compatible output connectors (CH-A, CH-B, Bridge)

Binding post output connectors

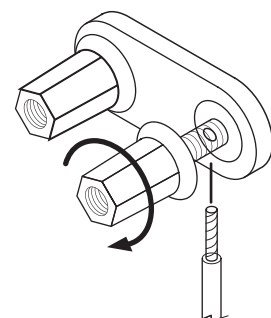
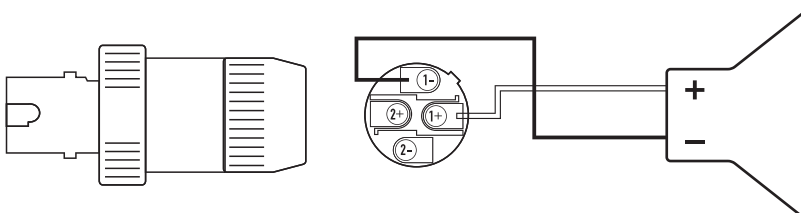

Technical Specifications

Parameter/Model	LPA500	LPA800	LPA1400	LPA1800	LPA2400	LPA3000
Power @ 80hm x2	125 W	200 W	280 W	360 W	500 W	650 W
Power @ 40hm x2	200 W	300 W	450 W	600 W	750 W	1000 W
Power @ 20hm x2	300 W	430 W	700 W	900 W	1200 W	1500 W
Power @ 80hm (Bridge)	400 W	600 W	900 W	1200 W	1500 W	2000 W
Power @ 40hm (Bridge)	500 W	800 W	1400 W	1800 W	2400 W	3000 W
Circuit	Class AB	Class AB	Class AB	Class H	Class H	Class H
Frequency Response	20Hz...20kHz ±1dB					
Input Sensitivity	6dBu (for rated power into 4Ω @ 1 kHz)					
THD	< 0.05%					
Damping factor	> 300 @ 8Ω					
Noise	100dB below rated output, 20Hz...20kHz @ 8Ω					
PSU	Transformer	Transformer	Transformer	Transformer	Transformer	Transformer
Fan	x 1 (var)	x 1 (var)	x 1 (var)	x 1 (var)	x 1 (var)	x 2 (var)
Width x Height (mm)	482.6x88	482.6x88	482.6x88	482.6x88	482.6x88	482.6x88
Depth (mm)	298 mm	298 mm	298 mm	395 mm	395 mm	395 mm
Weight (kg)	12.5 kg	13.0 kg	14.5 kg	15.0 kg	15.5 kg	19.5 kg
AC requirement	230V-50Hz*	230V-50Hz*	230V-50Hz*	230V-50Hz*	230V-50Hz*	230V-50Hz*
Power consumption @ 230V AC (1/8 power, pink noise)	2.5A	3A	3.5A	4A	4.5A	5A

* 110/120V version available on special request

Maintenance and warranty

While we have chosen the best components to make this product as rugged and reliable as possible, some parts in audio products (potentiometers, faders, switches) are subject to wear which is a matter of operation cycles, and not of time. While providing a full time-based warranty according to the country's of purchase requirements on the function of the electronic circuitry, we hence have to limit the warranty on such electro-mechanical parts to 90 days from the date of purchase.

In many cases, malfunction of electro-mechanical parts occurs due to dust contamination, which may require cleaning of such parts. As the inside of such parts is not accessible, a common practice is to use cleaning fluids in the shape of sprays. Please be reminded that many of such fluids contain chemicals which may wash away the dust but at the same time corrode or damage contact surface and may cause cosmetic damage to other parts. We hence explicitly exclude any claims for exchange of damaged part due to mechanical or chemical impact.

EC Declaration of Conformity

Manufacturer: Adelto Technologies Limited
Address: Vanguard Way, Shoeburyness, Essex SS3 9QY, UK

We declare on our own responsibility, that the equipment

Hill Audio LPA500
Hill Audio LPA800
Hill Audio LPA1400
Hill Audio LPA1800
Hill Audio LPA2400
Hill Audio LPA3000

is in conformity with the following directives and standards or regulations:

EMC Directive 2004/108/EC

EN55103-1:2009 (Emissions)
EN55103-2:2009 (Immunity)
EN61000-3-2:2006 + A1:2009 + A2:2009
EN61000-3-3:2008

LVD Directive 2006/95/EC

EN60065:2002 A1:2006 + A11:2008 + A2:2010

ROHS Directive 2002/95/EC

and is marked as follows:



Shoeburyness, 14. June 2013
Place and date of issuing

Authorized Signature

www.hill-audio.com



Hill Audio products are developed, manufactured and distributed by
Adelto Technologies
Vanguard Way, Shoeburyness, Essex SS3 9QY, UK
www.adelto.com | sales@adelto.com